

P-721 PIFOC® Piezo Flexure Objective Scanner

Fast Nanopositioner and Scanner for Microscope Objectives



P-721.CLQ piezo objective nanopositioning system with P-721.12Q QuickLock option and objective (adapter and objective not included)

- Scans and Positions Objectives with Sub-nm Resolution
- Travel Ranges to 140 μm, Millisecond Settling Time
- Significantly Faster Response and Higher Lifetime than Motorized Z-Stages
- Parallel Precision Flexure Guiding for Better Focus Stability
- Choice of Position Sensors: Capacitive Direct Metrology (Higher Performance) or Strain Gauge (Lower Cost)
- Compatible with Metamorph™ Imaging Software
- Outstanding Lifetime Due to PICMA® Piezo Actuators
- QuickLock Adapter for Easy Attachment

P-721 PIFOCs® are high-speed, piezo-driven microscope objective nanofocusing/scanning devices, providing a positioning and scanning range of 100 μm with sub-nanometer resolution and very high motion of linearity up to 0.03%.

Application Examples

- 3D-Imaging
- Z Stack Acquisition
- Screening
- Interferometry
- Metrology
- Disc-drive-testing
- Autofocus systems
- Confocal microscopy
- Biotechnology
- Semiconductor testing

PIFOCs® are also available with up to 460 μm travel (P-725 p. 2-28), and for exceptional dynamic and step performance (models P-726 p. 2-32 and P-725.SDD p. 2-30).

Superior Accuracy With Direct-Metrology Capacitive Sensors

Capacitive position feedback is used in the top-of-the-line models. PI's proprietary capacitive sensors measure position directly and without physical contact. They are free of friction and hysteresis, a fact which, in combination with the positioning resolution of well under 1 nm, makes it possible to achieve very high levels of linearity. A further advantage of direct metrology with capacitive sensors is the high phase fidelity and the high bandwidth of up to 10 kHz.

Alternatively, strain gauge sensor (SGS) models are available. The sensors are connected in a bridge configuration to eliminate thermal drift, and assure optimal position stability in the nanometer range.

Open-loop models are available for applications where fast response and very high resolution are essential. Here, specifying or reporting absolute position values is either not required or is handled by external sensors, such as interferometers, a vision system or photodiode PSD (position sensitive detector). These models retain the inherent piezo advantages such as high resolution and speed.

Simple Installation with QuickLock Thread Options

The PIFOC® is mounted between the turret and the objective with the QuickLock thread adapter. After threading the adapter into the turret, the Quick Lock is affixed in the desired position. Because the PIFOC® body need not to be rotated, cable wind-up is not an issue.

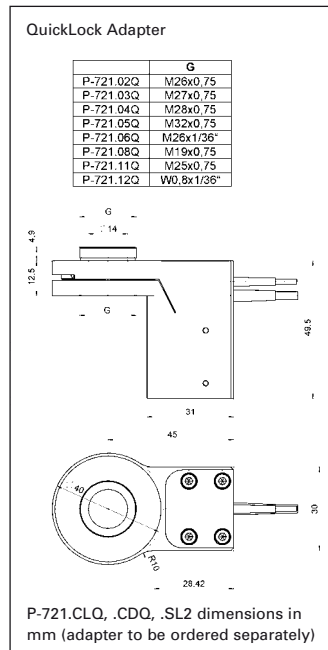

Ordering Information

P-721.CDQ

Fast PIFOC® Piezo Nanofocusing Z-Drive, 100 μm, Direct Metrology, Capacitive Sensor, Sub-D Connector, for Quick Lock Thread Adapters

P-721.CLQ

Fast PIFOC® Piezo Nanofocusing Z-Drive, 100 μm, Direct Metrology, Capacitive Sensor, LEMO Connector, for Quick Lock Thread Adapters

P-721.SL2

Fast PIFOC® Piezo Nanofocusing Z-Drive, 100 μm, SGS-Sensor, LEMO Connector, for Quick Lock Thread Adapters

P-721.0LQ

Fast PIFOC® Piezo Nanofocusing Z-Drive, 100 μm, No Sensor, LEMO Connector, for Quick Lock Thread Adapters

Extension Tubes for Objectives

P-721.90Q

Extens. Tube, 12.5 mm, Thread W0.8 x 1/36°

P-721.91Q

Extens. Tube, 12.5 mm, Thread M25 x 0.75

P-721.92Q

Extens. Tube, 12.5 mm, Thread M26 x 0.75

P-721.93Q

Extens. Tube, 12.5 mm, Thread M27 x 0.75

P-721.94Q

Extens. Tube, 12.5 mm, Thread M28 x 0.75

P-721.95Q

Extens. Tube, 12.5 mm, Thread M32 x 0.75

P-721.96Q

Extens. Tube, 12.5 mm, Thread M26 x 1/36°

P-721.98Q

Extens. Tube, 12.5 mm, Thread M19 x 0.75

QuickLock Thread Adapters see figure

High Reliability and Long Lifetime

The compact PIFOC® systems are equipped with preloaded PICMA® high-performance piezo actuators which are integrated into a sophisticated, FEA-modeled, flexure guiding system. The PICMA® actuators feature cofired ceramic encapsulation and thus offer better performance and reliability than conventional piezo actuators. Actuators, guidance and sensors are maintenance-free and not subject to wear, and thus offer an extraordinary reliability.

Choice of Controllers

A large choice of analog and digital piezo controllers as OEM, bench-top and 19-inch-rackmount versions is available.



Technical Data

Model	P-721.CLQ	P-721.CDQ	P-721.SL2	P-721.0LQ	Units	Tolerance
Active axes	Z	Z	Z	Z		
Motion and positioning						
Integrated sensor	Capacitive	Capacitive	SGS	–		
Open-loop travel, -20 to +120 V	140	140	140	140	µm	min. (+20%/-0%)
Closed-loop travel	100	100	100	–	µm	calibrated
Open-loop resolution	0.5	0.5	0.5	0.5	nm	typ.
Closed-loop resolution	0.7	0.7	5	–	nm	typ.
Linearity, closed-loop	0.03	0.03	0.2	–	%	typ.
Repeatability	±5	±5	±10	–	nm	typ.
Runout θX, θY	13	13	13	13	µrad	typ.
Crosstalk X, Y	100	100	100	100	nm	typ.
Mechanical properties						
Stiffness in motion direction	0.3	0.3	0.3	0.3	N/µm	±20 %
Unloaded resonant frequency	580	580	580	550	Hz	±20 %
Resonant frequency @ 120 g	235	235	235	235	Hz	±20 %
Resonant frequency @ 200 g	180	180	180	180	Hz	±20 %
Push/pull force capacity in motion direction	100 / 20	100 / 20	100 / 20	100 / 20	N	Max.
Drive properties						
Ceramic type	PICMA® P-885	PICMA® P-885	PICMA® P-885	PICMA® P-885		
Electrical capacitance	3.1	3.1	3.1	3.1	µF	±20 %
Dynamic operating current coefficient	3.9	3.9	3.9	3.9	µA/(Hz·µm)	±20 %
Miscellaneous						
Operating temperature range	-20 to 80	-20 to 80	-20 to 80	-20 to 80	°C	
Material	Aluminum	Aluminum	Aluminum	Aluminum		
Mass	0.24	0.24	0.22	0.22	kg	±5 %
Max. objective diameter	39	39	39	39	mm	
Cable length	1.5	1.5	1.5	1.5	m	±10 mm
Sensor / voltage connection	LEMO	Sub-D Special	LEMO	LEMO (no sensor)		
Recommended controller / amplifier	E-610 servo controller/amplifier (p. 2-110), modular piezo controller system E-500 (p. 2-142) with amplifier module E-505 (high performance) (p. 2-147) and E-509 servo controller (p. 2-152)	E-625 servo controller, bench top (p. 2-114), E-665 powerful servo controller, bench-top (p. 2-116), Single-channel digital controller: E-753 (bench-top) (p. 2-108)	E-610 servo controller/amplifier, E-625 servo controller, bench-top, E-665 powerful servo controller, bench-top	E-610 servo controller/amplifier		

Resolution of PI Piezo Nanopositioners is not limited by friction or stiction. Value given is noise equivalent motion with E-503 amplifier (p. 2-144)

Linear Actuators & Motors

Nanopositioning / Piezoelectrics

Piezo Flexure Stages / High-Speed Scanning Systems

Linear

Vertical & Tip/Tilt

2- and 3-Axis

6-Axis

Fast Steering Mirrors / Active Optics

Piezo Drivers / Servo Controllers

Single-Channel

Multi-Channel

Modular

Accessories

Piezoelectrics in Positioning

Nanometrology

Micropositioning

Index