

Digital CCD Camera C8484-03G01

For Biomedical Systems, Industrial Inspection and Machine Vision



▲ C8484-03G01

The C8484-03G01 is a high-resolution digital camera using a progressive scan interline CCD with no mechanical shutter. In addition to a high resolution of 1.37 million pixels, a wide dynamic range of 12 bit digital output and high sensitivity in the VIS-NIR region offers a wide application range down to low light level imaging.

The C8484-03G01 employs a hermetic vacuum-sealed head which can be cooled to -10 °C. The outputs data is transmitted via an IEEE 1394 interface.

FEATURES

- High resolution of 1.37 million pixels
- High sensitivity in VIS-NIR region
- Progressive scan interline CCD chip with no mechanical shutter
- Anti-blooming function
- Wide dynamic range
- Small readout noise of 6 to 8 electrons
- Low dark current with peltier cooling (0.1 electrons/s/pixel)
- High frame rate of 43 frame/s (8×8 binning)



SPECTRAL RESPONSE

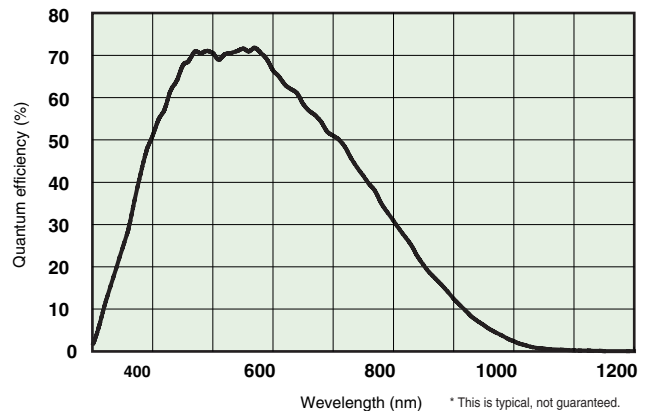

APPLICATIONS

- Routine fluorescence microscopy
- Green fluorescent protein applications
- DNA and ploidy analysis
- Red and near infrared fluorescent applications
- Fluorescence In-situ hybridization studies
- Motility and motion analysis
- Combined DIC / phase and fluorescence microscopy
- Histology, pathology and cytology
- Metallurgical microscopy
- Failure analysis
- Semiconductor inspection
- X-ray scintillator readout

SYSTEM CONFIGURATION

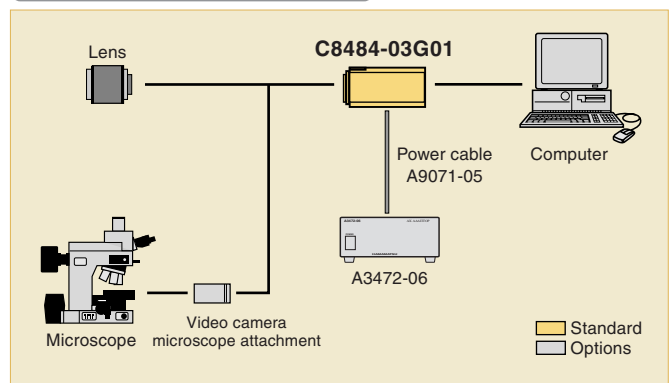

SYSTEM SPECIFICATIONS

Type number	C8484-03G01		
Imaging device	Progressive scan interline CCD with micro-lens		
Pixels number	1344 (H) × 1024 (V)		
Cell size	6.45 mm (H) × 6.45 mm (V) (square format)		
Effective area	8.67 mm (H) × 6.60 mm (V) (2/3-inch format)		
Pixel clock rate	14.7 MHz/pixel		
Frame rate	binning	1 × 1	8.9 frame/s
		2 × 2	16.3 frame/s
		4 × 4	27.8 frame/s
		8 × 8	43.0 frame/s
Readout noise(r.m.s.)	6 to 8 electrons r.m.s. (typ.)		
Full well capacity	15 000 electrons		
Dynamic range*	2142 : 1		
Dark current	0.1 electrons/s/pixel		
Cooling temperature	- 10 °C		
A/D converter	12 bit		
Exposure time	10 μs to 10 s		
Sub-array	Yes		
Contrast enhancement	High gain / Low gain		
External trigger	Yes		
Lens mount	C-mount		
Digital output	IEEE 1394-1995		
External control	IIDC1394-Based Digital Camera Specification Ver.1.30		
Power requirements	DC+12 V 2 A		
Power consumption	24 V·A		
Ambient storage temperature	- 10 °C to + 50 °C		
Ambient operating temperature	0 °C to + 40 °C		
Ambient operating/storage humidity	70 % max. (with no condensation)		

*Calculated from the ratio of the full well capacity and the average readout noise.

OPTIONS

- **AC adaptor** : **A3472-06**
 - Line voltage : 100 V to 240 V AC input
 - Output voltage : DC +12 V
- **Power cable** : **A9071-05**
 - Cable length : 5 m

DIMENSIONAL OUTLINES

(Unit : mm)

● C8484-03G01

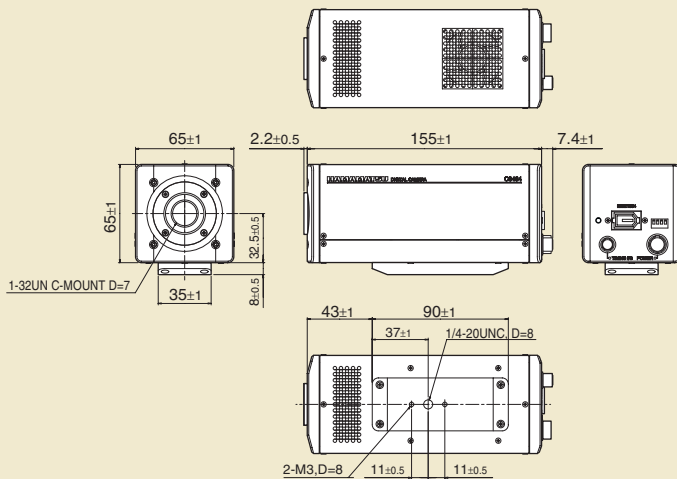

(Weight : approx. 0.6 kg)

● AC adaptor A3472-06

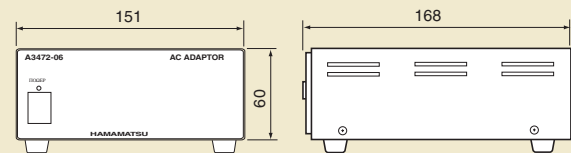

(Weight : approx. 0.8 kg)

★ **Product and software package names noted in this documentation are trademarks or registered trademarks of their respective manufacturers.**

- Subject to local technical requirements and regulations, availability of products included in this promotional material may vary. Please consult with our sales office.
- Information furnished by HAMAMATSU is believed to be reliable. However, no responsibility is assumed for possible inaccuracies or omissions. Specifications and external appearance are subject to change without notice.

© 2008 Hamamatsu Photonics K.K.

HAMAMATSU

Homepage Address <http://www.hamamatsu.com>

HAMAMATSU PHOTONICS K.K., Systems Division

812 Joko-cho, Higashi-ku, Hamamatsu City, 431-3196, Japan, Telephone: (81)53-431-0124, Fax: (81)53-435-1574, E-mail: export@sys.hpk.co.jp

U.S.A. and Canada: Hamamatsu Corporation, Systems Division: 360 Foothill Road, Bridgewater, N.J. 08807-0910, U.S.A., Telephone: (1) 908-231-0960, Fax: (1)908-231-0852, E-mail: usa@hamamatsu.com

Germany: Hamamatsu Photonics Deutschland GmbH: Arzbergerstr. 10, D-82211 Herrsching am Ammersee, Germany, Telephone: (49)8152-375-0, Fax: (49)8152-2658, E-mail: info@hamamatsu.de

France: Hamamatsu Photonics France S.A.R.L.: 19, Rue du Saule Trapu, Parc du Moulin de Massy, 91882 Massy Cedex, France, Telephone: (33)1 69 53 71 00, Fax: (33)1 69 53 71 10, E-mail: infos@hamamatsu.fr

United Kingdom: Hamamatsu Photonics UK Limited: 2 Howard Court, 10 Tewin Road, Welwyn Garden City, Hertfordshire, AL7 1BW, U.K., Telephone: (44) 1707-294888, Fax: (44) 1707-325777, E-mail: info@hamamatsu.co.uk

North Europe: Hamamatsu Photonics Norden AB: Smidesvägen 12, SE-171-41 Solna, Sweden, Telephone: (46)8-509-031-00, Fax: (46)8-509-031-01, E-mail: info@hamamatsu.se

Italy: Hamamatsu Photonics Italia S.R.L.: Strada della Moia, 1/E 20020 Arese (Milano), Italy, Telephone: (39)02-935 81 733, Fax: (39)02-935 81 741, E-mail: info@hamamatsu.it

Cat. No. SCAS0049E02

APR/2008 HPK

Created in Japan (PDF)